



## SERVICE BULLETIN NO. MSB1078-126/1

### **I. TECHNICAL DETAILS**

#### **1.1 Category:**

Mandatory

#### **1.2 Airplanes affected:**

G 115, G 115A, G 115B                      all S/N

#### **1.3 Time of Compliance:**

next 50 hours inspection after receipt of material, but not later than 31 December 2003

#### **1.4 Subject:**

ATA-Code:    N/A  
CO in cockpit

#### **1.5 Reason:**

Under disadvantageous circumstances (i.e. leaky seals) / flight manouvers (i.e. pull out) it might occur, that the CO concentration in the cockpit increases. A few different precautionary actions must be performed to prevent this.

#### **1.6 Concurrent documents:**

N/A

#### **1.7 Approval Note:**

These information or instructions relate to change no. MÄM 1078-38 which has been approved under the authority of JAA Design Organisation Approval No. LBA.NJA.008.

The technical information contained in this document has been approved under the authority of JAA Design Organisation Approval No. LBA.NJA.008.

**G 115/ G 115A/ G 115B**



## 1.8 Accomplishment/ Instructions

- 1.8.1 Close LH and RH, upper and lower wing / fuselage transition using silicone (i.e. HENKEL F 109) or alternatively tesa tape (i.e. type 4651, 25 mm wide).

**Note:** If transition is already closed, check condition, especially for perforation. If required reseal transition newly.

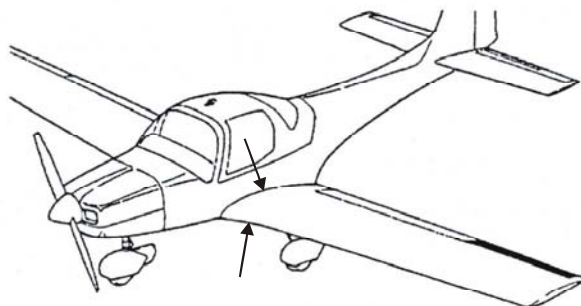

- 1.8.2 Install covers P/N 115B-1053/1 and 115B-1054/1 to the LH and RH landing gear leg as follows:

**NOTE:** Only applicable for G 115/ G 115A. On G 115B the covers had been already installed during the modification IAW SB 1078-27/2 !

- install cover to the LH and RH landing gear leg and determine position for the front strap

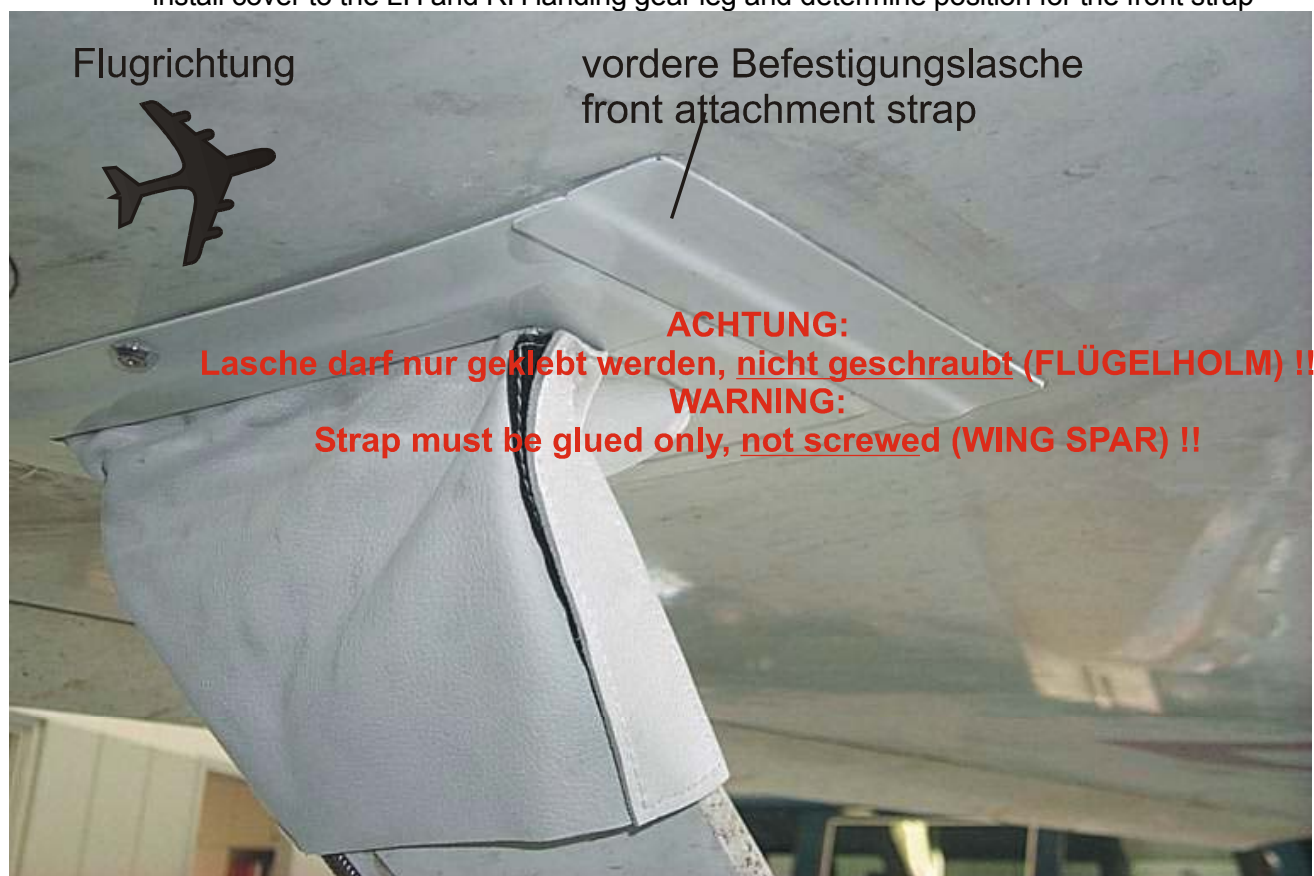

- grind carefully lower wing surface at the glueing area of the front strap (remove paint, don't damage the fabric)
- apply strap using resin/ hardener system L 20/ VE 2723. Press on strap and allow glueing area to harden.



- install cover using 4 screws P/N DIN7973-3,5x13 and collars P/N US4125 Form 4  
**CAUTION: The front attachment strap must not be screwed on (DANGER FOR THE WING SPAR !!)**

1.8.3 Replace the loudspeaker cover in the baggage compartment as follows:

- remove screws (item 460, qty. 8) and remove loudspeaker covers (item 450)
- install new cover plate P/N 115E-2000.40 using screws (item 460)

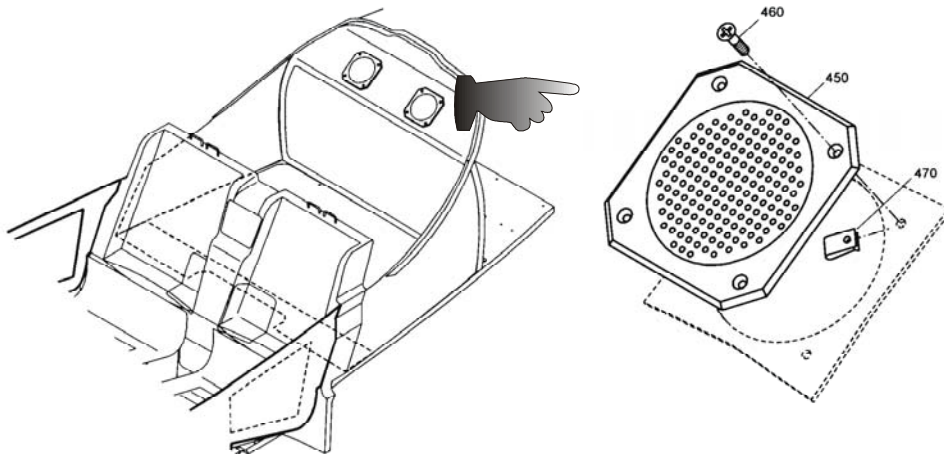

G 115/ G 115A/ G 115B



### **1.9 Repetitive Actions**

None.

### **1.10 Mass (Weight) and CG:**

N/A

## **II. PLANNING INFORMATION**

### **2.1 Material & Availability:**

Item	P/N	Name	Qty.
1	115B-1053/1	Landing gear leg cover	1
2	115B-1054/1	Landing gear leg cover	1
3	DIN7973-3,5x13	Screw	4
4	US4125 Form 4	Collar	4
5	115E-2000.40	Cover	2
6	L20	Resin	AR
7	VE2723	Hardener	AR
8	HENKEL F 109	Silicone	AR
	4651, 25 mm wide	Tesa tape	AR

### **2.2 Special Tools:**

N/A

### **2.3 Labour costs:**

approx. 1,0 hour (without curing and post-curing times)

### **2.4 Reference documents:**

N/A

G 115/ G 115A/ G 115B



### **2.5 Credit:**

N/A

## **III. REMARKS**

- 3.1 The correct execution of the instructions may be performed by a competent person/ an authorised aviation workshop and has to be certified in the logbook by an authorised inspector.
- 3.2 If you have sold your aircraft in the meantime, would you kindly pass this information on to the new owner and forward his address and aircraft S/N to us.
- 3.3 For questions and assistance please contact:

Rudi Vodermeier , Head of Product Support,  
phone: +49 8268 998139  
fax: +49 8268 998200  
e-mail: [productsupport@grob-aerospace.de](mailto:productsupport@grob-aerospace.de)