

SERVICE BULLETIN NO. MSB1078-163

I. TECHNICAL DETAILS

1.1 Category:

Mandatory

1.2 Aircraft affected:

Description	LBA TCDS	EASA TCDS	FAA TCDS	Serial-Nr.
G 115C	1078	EASA.A.364	A57EU	82001-82084 (C)
G 115C2	1078	EASA.A.364	A57EU	82001-82084 (C2)
G 115D	1078	EASA.A.364	A57EU	82001-82084 (D)
G 115D2	1078	EASA.A.364	A57EU	82001-82084 (D2)
G 115E	1078	EASA.A.364		82086/E-82185/E
G 115EG	1078	EASA.A.364	A57EU	82200-82273

1.3 Time of Compliance:

Latest next 200 hours inspection or annual inspection/ airworthiness review, what ever comes first

1.4 Subject:

ATA-Code: 20-10 Standard Practices - Airframe
 57-10 Wing Structure

1.5 Reason:

During final assembly of a new series production aircraft it was revealed, that the corresponding Maintenance Manuals give different and incorrect torque values for the wing shear force fitting nuts, although the approved design data give the correct value.

Therefore the nuts at the affected aircraft may not have been tightened to the correct value during maintenance and repair activities and as precautionary action the torque has to be checked and corrected, if required.

G 115C/D/E/EG

1.6 Concurrent documents:

N/A

1.7 Approval Note:

These information or instructions relate to change no. MÄM 1078-100 which has been approved under the authority of EASA Design Organisation Approval No. EASA.21J.030.

The technical information contained in this document has been approved under the authority of EASA Design Organisation Approval No. EASA.21J.030.

1.8 Accomplishment / Instructions:

- 1.8.1. Ensure that the aircraft is safe for parking I.A.W. MM chapter 10-10.
- 1.8.2. Remove the baggage compartment panel to get access to the RH and LH rear wing shear bolts (Fig. 1) I.A.W. MM chapter 25-10.

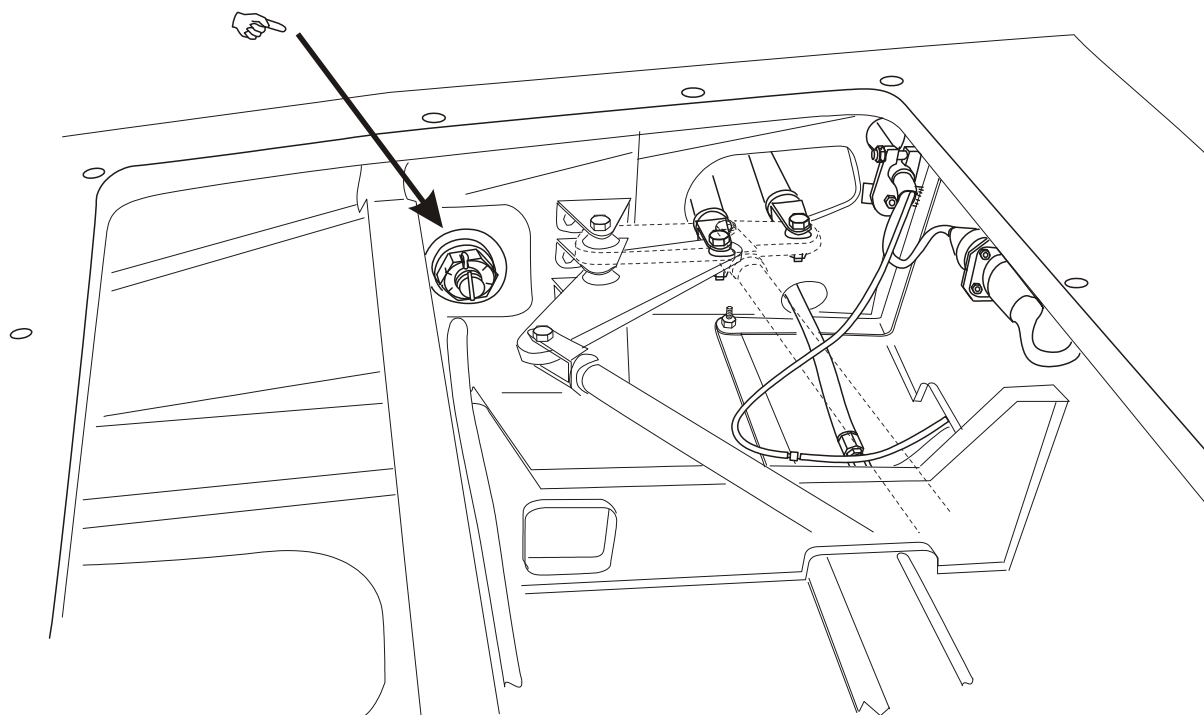

Fig.1

G 115C/D/E/EG

- 1.8.3. Release the cockpit trim panel in front of the pilots seat to get access to the RH and LH front wing shear bolts I.A.W. MM chapter 25-10 (Fig. 2).

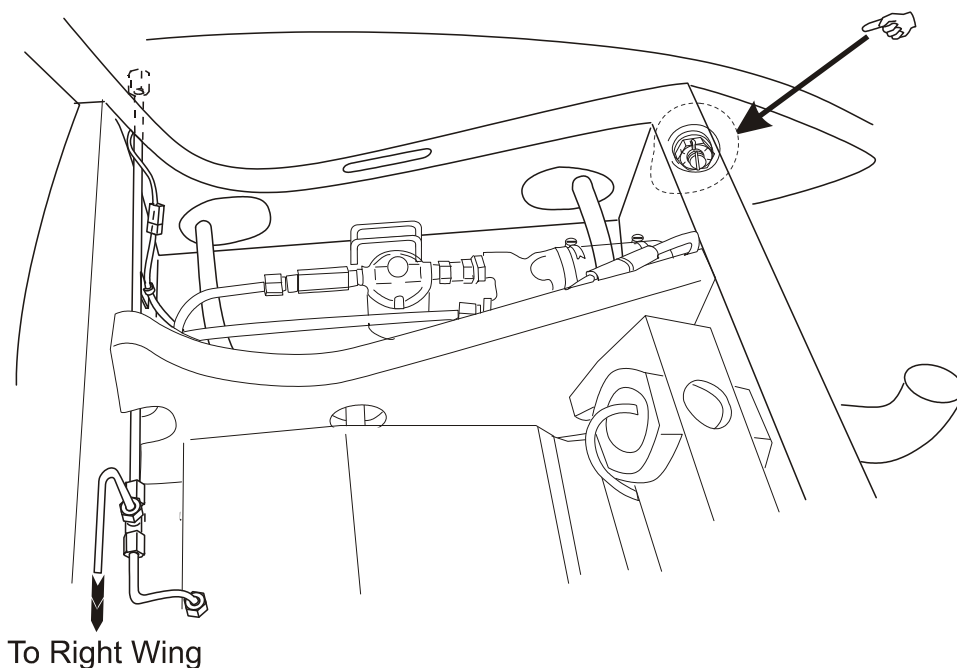

Fig. 2

- 1.8.4. Remove cotter pin LN94-4x30 (Fig. 3, item 160) from each wing shear bolt.

- 1.8.5. Release castellated nut P/N LN9345-M16x1,5 (Fig. 3, item 150) as follows:

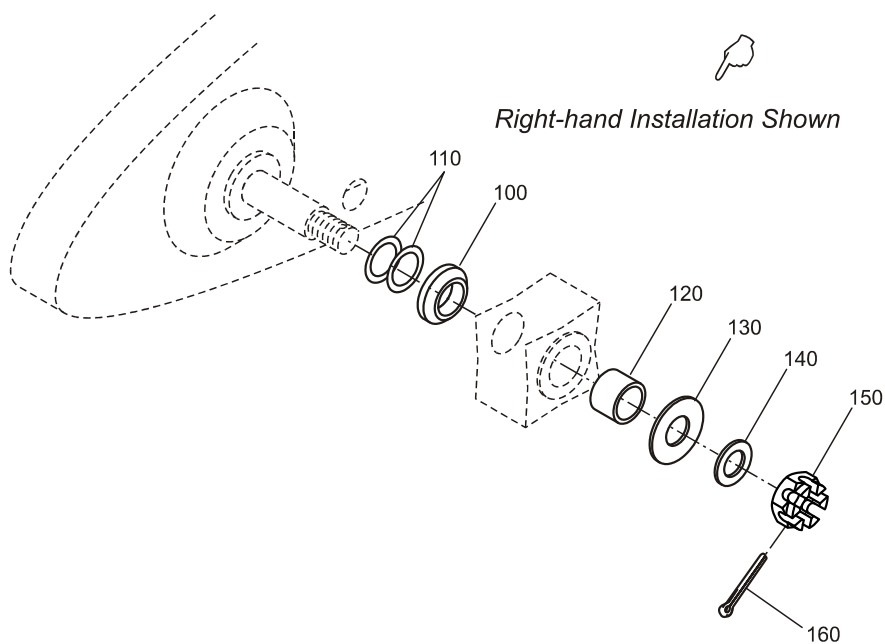

Fig. 3

G 115C/D/E/EG

Notes: It is recommended to check one side after the other. Check LH and RH side before removing wings, if required.

Recommended sequence: LH side first, then RH side

Perform the following work steps on the front and rear bolt at the same time.

If shimming is required, it is only necessary on the first checked side.

- turn open both nuts a half turn
- if washers underneath are turnable, the shimming between wing and fuselage is correct and you may proceed with para. 1.8.6
- if washers underneath is not turnable, proceed as follows:
 - release castellated nuts further stepwise by 1/3 turns until washer is turnable. Note number of 1/3 turns to determine required additional shims (1 whole turn = 1.5mm, thread pitch)
 - remove wing I.A.W. MM chapter 57-10
 - install additional shims P/N 115C-1001.28 (Fig. 3, item 110, thickness 0.5mm) as required
 - install wing I.A.W. MM chapter 57-10

1.8.6. Torque each castellated nut with **20 - 50 Nm (14.75 – 36.87 lbf.ft)**.

1.8.7. Install cotter pin LN94-4x30 to each wing shear bolt.

1.8.8. Install the cockpit trim panel in front of the pilots I.A.W. MM chapter 25-10.

1.8.9. Install the baggage compartment panel I.A.W. MM chapter 25-10.

1.9 Repetitive Actions:

The correct torque value of

20 – 50 Nm (14.75 – 36.87 lbf.ft)

must be used during each wing installation. Until the corresponding Maintenance Manuals are corrected within the next regular revision, the correct value should be entered handwritten into the AMM Chap. 20 and 57.

1.10 Mass (Weight) and CG:

N/A

G 115C/D/E/EG

II. PLANNING INFORMATION

2.1 Material & Availability:

Item	P/N	Description	Qty. / A/C
1	LN94-4x30	Cotter Pin	4
1	115C-1001.28	Shim	AR

2.2 Special Tools:

N/A

2.3 Labour costs:

N/A

2.4 Reference documents:

Corresponding G 115 models Maintenance Manual and Illustrated Parts Catalogue

2.5 Credit:

N/A

III. REMARKS

- 3.1 The correct execution of the instructions may be performed by a competent person/ an authorised aviation workshop and has to be certified in the logbook by an authorised inspector.
- 3.2 The corresponding Maintenance Manuals will be updated to reflect the changes.
- 3.3 If you have sold your aircraft in the meantime, would you kindly pass this information on to the new owner and forward his address and aircraft S/N to us.
- 3.4 For questions and assistance please contact:

Rudolf Vodermeier, Head of Customer Service & Support

phone: +49 8268 998 139

fax: +49 8268 998 200

e-mail: productsupport@grob-aircraft.com

SB-Index: <http://www.grob-aircraft.eu/service-and-support/g-115.html>

Order: <http://www.grob-aircraft.eu/service-and-support/general/order-form.html>

G 115C/D/E/EG